

UHF SERIES WIRELESS MICROPHONE OPERATION MANUAL

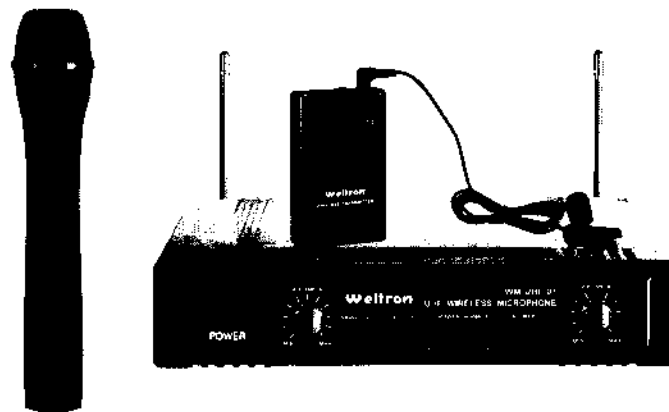

BEFORE ATTEMPTING TO CONNECT, OPERATE OR ADJUST THIS PRODUCT, PLEASE READ THIS MANUAL COMPLETELY.

PREFACE

We strongly suggest that you carefully study these instructions before attempting to operate the system, and that you note all the listed precautions.

CONTENTS

P2	Precautions
P3	Hand-held Microphone
P4	Receiver Unit/Operation
P5	Bodypack Microphone
P6	Installation
P7	Trouble shooting
P8	Specifications

PRECAUTIONS

- Avoid exposure of the system to rain or moisture.
- No user-serviceable parts inside the system. Refer all servicing to a qualified technician only.
- Handle the microphone carefully, dropping or other shocks may cause failure.
- Avoid using the system where it may be subjected to heat, such as in direct sunlight, near radiators or other heat sources.
- Should any liquid be spilled on the system, stop using it immediately. It may be possible to dry the system, but you should have it checked by a qualified technician before using it again.
- Take care with the mains power adapter and lead. If damaged in any way, do not use the system, and refer to a qualified technician for repair.
- Only use the system with the supplied components, do not attempt to use with any other mains power supply adapter or microphone.
- If the microphone is not going to be used for a time, remove the battery to prevent leakage. In the event of electrolyte leakage inside the battery compartment, carefully remove using a damp cloth. Take care not to get battery electrolyte in contact with your skin, however, if it does, wash your hands under a running tap. If electrolyte comes into contact with your eyes, seek medical advice immediately.
- Only replace the battery with the same or an equivalent type.
- Please dispose of old batteries in an environmentally friendly manner in accordance with the relevant legislation.
- Do not use any solvents to clean any part of the radio microphone system.

HANDHELD MICROPHONE

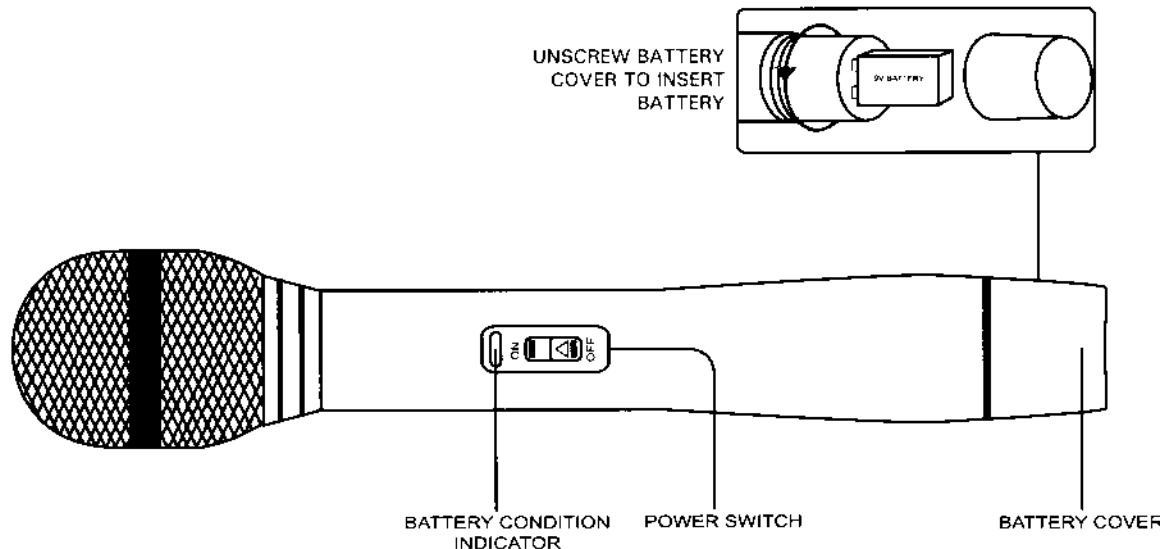

OPERATION

1. Unscrew the battery cover at the end of the microphone. Install the provided 9 volt battery, taking care to fit it with the correct polarity connected.
2. Check the battery by switching the microphone ON. The red LED will come on for one second and then go OFF, this indicates correct operation. If the red LED stays ON or is dim, this indicates the battery is low and should be changed.
3. If the red LED does not come on at all, it indicates the battery is dead, please change it right now.

RECEIVER UNIT/OPERATION

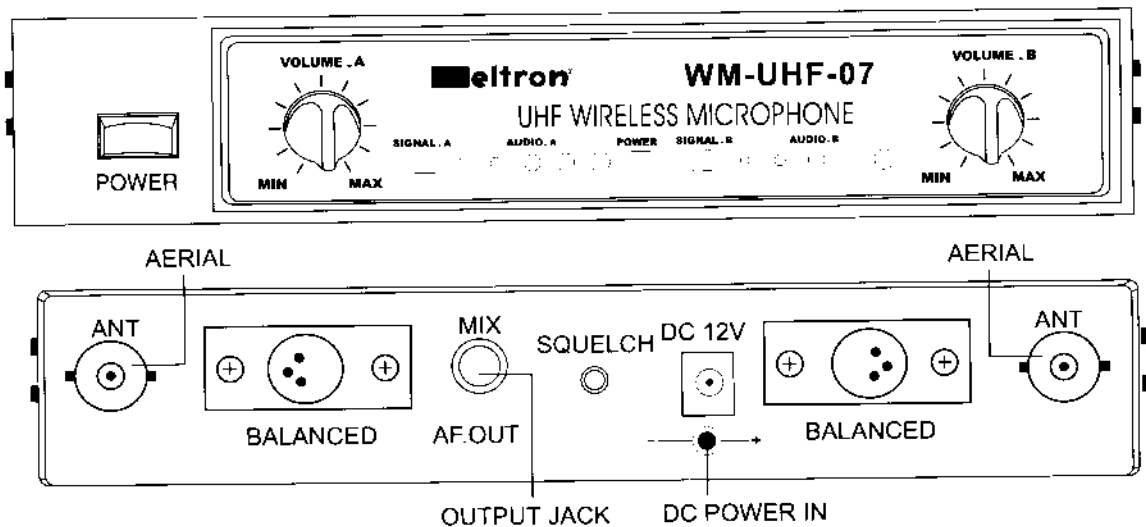

OPERATION

Switch on the wireless microphone receiver unit by pressing the POWER switch and the POWER light will illuminate to show the receiver unit is working. Raise the aerials to the maximum height. The positioning of the aerials is not critical for performance; ideally they should be fully extended. Switch ON the microphone, checking that the red LED comes on for a second and then goes off. When the microphone is ON, the SIGNAL light will illuminate on the receiver unit.

The wireless microphone is now ready for use; adjust the volume and tone levels of your amplifier system as well as the receiver & the bodypack as required. When the wireless microphone is not being used, turn OFF the microphone.

Note that switching the microphone on and off can cause interference that will be heard if the microphone volume level of the amplifier system is still set high.

BODYPACK TRANSMITTER

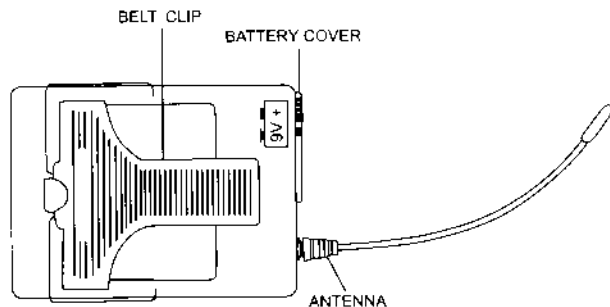
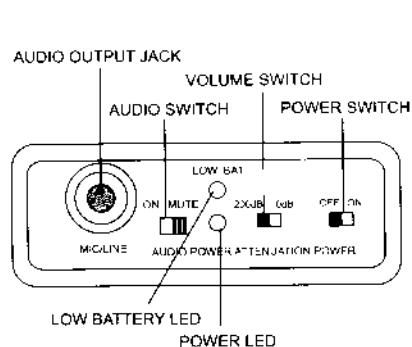

OPERATION

Open the battery cover to install a 9V battery as per correct polarities. Put the power switch to ON position, the power indicator will be green to show normal working. If the LOW BAT indicator comes to red while the power indicator comes out from green, this indicates the voltage is not enough for operation, we must take another new battery for replacement, so it will work continuously.

Before operation, please confirm that the frequency of transmitter should be same as the frequency of receiver. Plug the 3.5mm connector of headset mic to screw-lock socket of transmitter. Put the audio switch to ON position, speak to the mic head exactly but keep 2-3cm distance between mouth and mic head. When you are close to the amplifier, please put the audio switch to MUTE position to avoid humming. ATTENUATION is for volume adjustment. Put it to 0dB position to get normal volume output, or put it to -20dB position to reduce distortion and avoid humming.

If the system will not be used for a long time, please switch off the transmitter to avoid power consumption.

INSTALLATION

To connect the wireless microphone to your amplifier system:

- Refer to the installation diagram below.
- Using the supplied screened jack-to-jack lead, connect from the AF. OUT jack socket to the MICROPHONE INPUT socket on your amplifier. Plug the mains power adapter into a suitable mains socket, and plug the lead connector into the DC 12V input socket.

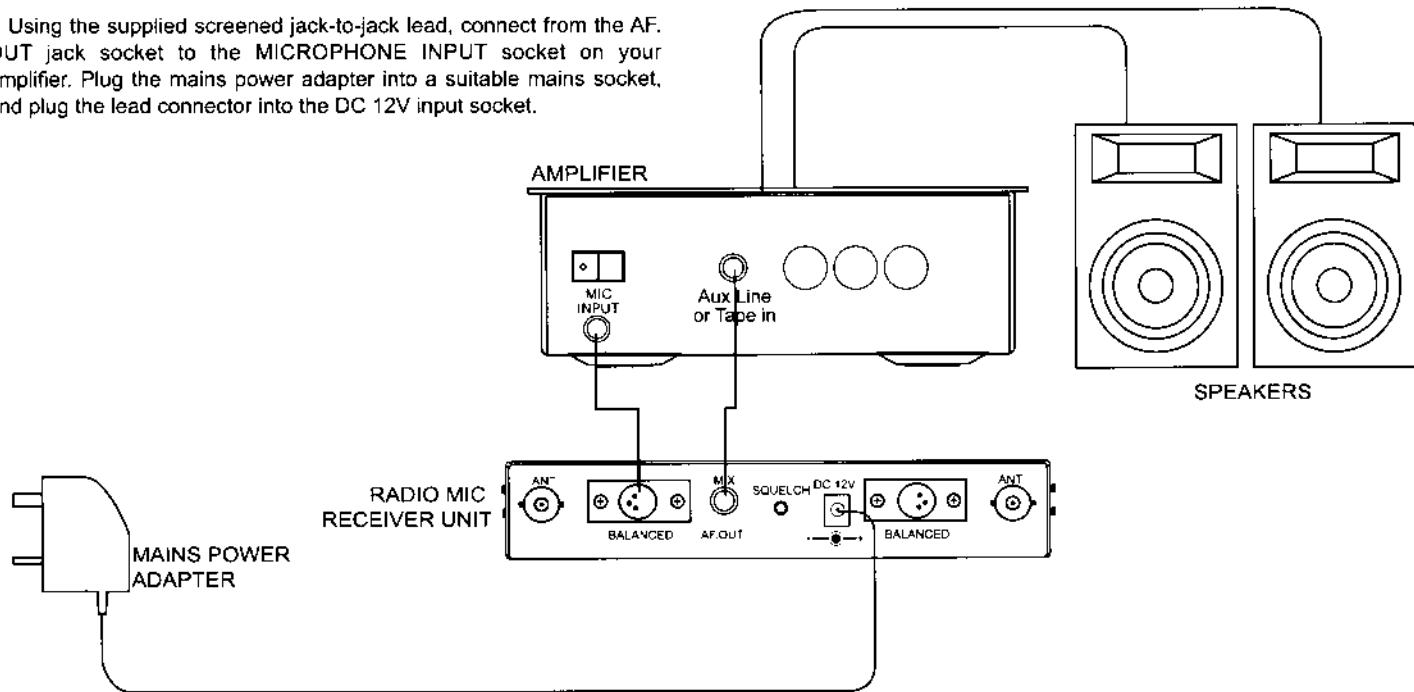

TROUBLE SHOOTING

Please read and check the following points before asking for service.

The wireless microphone fails to work:

- Check the microphone battery by switching the microphone ON - the red LED battery condition indicator should come on for a second and then go off. If the red LED stays on or is dim, replace the battery. If the red LED fails to come on, check the battery polarity or change battery.
- Check the POWER indicator on the receiver unit is ON - if not, check the mains power adapter is firmly plugged into a working mains socket.
- Check the amplifier system is ON and the microphone controls set correctly.
- Check the radio microphone jack lead is firmly connected into the output socket on the rear panel of the receiver unit, and into the MIC input socket on your amplifier.

The working range is limited:

- Check the microphone battery condition (see above)
- Check the aerials are fully extended. Adjust the position of the aerials to achieve the best reception.

Feedback (howl-round) is heard:

- Check that the microphone is not being used too close to, or in front of, the loudspeakers.
- Check the settings of the microphone controls on the amplifier, adjust volume and tone to get the best sound without any trace of feedback.

SPECIFICATIONS

A. Overall system

1. Oscillation mode: Quartz controlled
2. Carrier Frequency Range: UHF690-960MHz
3. Frequency: 28 non-interference fixed frequencies
4. Stability: +/-0.005%
5. Max Deviation: +/-56KHz with level limiting
6. Dynamic Range: >110dB
7. S/N Ratio: >100dB
8. T. H. D: <0.5dB
9. Squelch: "Pilotone & Noiselock" dual squelch circuit
10. Frequency Response: 60Hz-18KHz

B. Receiver

1. Sensitivity: 6dB μ V at S/N >70dB
2. Image Rejection: >60dB
3. Stability: >80dB
4. Audio output: -12db/600ohm unbalanced and balanced
5. Power supply: 12V-15VDC/0.5A power supply
6. Dimensions(m/m): 213x148x45
7. Weights: 1.0KGS approx

C. Wireless microphone

1. Mike capsule: Dynamic microphone(Handheld mic)
Condenser Microphone(Headset mic/clip-on mic)
2. Antenna: Built-in housing(Handheld transmitter)
Built-out housing(Belt pack transmitter)
3. RF Output : >10mw (according to regulation)
4. Spurious: <-40dBC
5. Battery: one 9V battery